



# Pilkington Profilit™

Technical Information on Pilkington Profilit™  
Profiled Glass with System

- English Edition -



# The Pilkington **Profilit**™ Product Range

Physical characteristics and dimensions

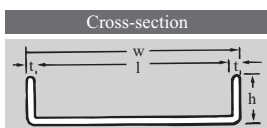

Tolerances:  $w \pm 2.0$  mm  
 $t \pm 0.2$  mm  
 $h \pm 1.0$  mm

Cutting tolerances of  $\pm 3$  mm are allowed.

The Pilkington **Profilit**™ product range comprises 4 standard profiles (K 22<sup>(\*)</sup>, K 25, K 32, K 50) and 3 special profiles (K 22/60/7, K 25/60/7, K 32/60/7).

Both standard (NP) and special profiles (SP) are also available with longitudinal wires.

The range of profile options available in terms of width, flange height and glass thickness means that almost all glazing requirements are catered for.

- In addition to the maximum lengths indicated, all other lengths in multiples of 25 cm starting from 100 cm can be supplied. Fixed dimension lengths are possible on request.
- Research has shown that interiors fitted with ornamented glass rather than plain glass enjoy significantly enhanced light capture.

Pilkington <b>Profilit</b> ™ types <sup>1</sup>		K 22 <sup>(*)</sup>	K 25	K 32	K 50	K22/60/7	K25/60/7	K32/60/7	
Dimensions	Designation as per DIN 1249 / EN 572 Part 7	A <sup>(*)</sup>	C	E	G	B	D	F	
	Width w (mm)	232	262	331	498	232	262	331	
	Flange height h (mm)	41	41	41	41	60	60	60	
	Glass thickness t (mm)	6	6	6	6	7	7	7	
	Weight (single-glazing) kg/m <sup>2</sup>	19,5	19,0	18,2	17,0	25,5	24,5	22,5	
Pilkington <b>Profilit</b> ™ with wire	Max. length supplied mm (not max. installation length)	6000	6000	6000	5000	7000	7000	7000	
	Number of longitudinal wires	7 <sup>(*)</sup>	8	10	16 <sup>(*)</sup>	7	8	10	
	With 16 longitudinal wires (meshing function)	-	16	-	-	-	16	-	
Pilkington <b>Profilit</b> ™ functional glass	For facades**	-	-	-	-	-	8+2*	-	
	Heat insulating glass éplus 1.7'	-	S	S	S	S	S	S	
	Heat insulating glass 'plus 1.7 wired'	-	S	S	-	-	S	S	
	Sun-protection glass 'Antisol'	-	S	S	S	S	S	-	
Pilkington <b>Profilit</b> ™ colours / ornamentation	Sun-protection glass 'Antisol wired'	-	S	S	-	-	S	-	
	Amethyst	-	S	S	-	-	S	-	
	Amethyst wired	-	S	-	-	-	S	-	
	Pilkington <b>Profilit</b> ™ clear (without ornamentation)	-	S <sup>(*)</sup>	-	S <sup>(*)</sup>	-	S <sup>(*)</sup>	-	
Performance	Pilkington <b>Profilit</b> ™ clear wired (without ornamentation)	-	S	-	-	-	-	-	
	Light permeability in % (mean value)	SG: 86%			DG: 75%				
	Heat transmission coefficient U <sub>G</sub> (W/m <sup>2</sup> x K)	SG: 5,6		DG: 2,8		SG: 5,52		DG: 2,7	as A-G
	Sound insulation value R <sub>w</sub> from 100-3200 Hz	SG: 22 dB			DG: 38 dB***		SG: 25 dB		DG: 41 dB***
<sup>(*)</sup> One wire per flange <sup>(**)</sup> For Pilkington <b>Profilit</b> ™ facades, consult our technical applications department prior to usage <sup>(***)</sup> Glass installation using Pilkington <b>Profilit</b> ™ gaskets nos. 165 and 166									

**Pilkington Profilit™ thermally toughened**  
 Pilkington **Profilit**™ T and Pilkington **Profilit**™ T Color thermally toughened profiled glass with or without heat soak-test upon request. The supply lengths and maximum installation lengths provided in this document do not apply for Pilkington **Profilit**™ T and Pilkington **Profilit**™ T Color.

**For the application of Pilkington Profilit™ the relevant national and international requirements and standards have to be considered in the various countries.** We would be pleased to examine the possibility of supplying any product combination not mentioned above upon request.

**Note:** e.g. K 22 = 36 dB without padding, 38 dB with padding = R<sub>w</sub>.

**Heat transmission coefficient U<sub>G</sub>:** W/m<sup>2</sup> x K; amount of heat that passes through a unit area of 1 m<sup>2</sup> of a material of a unit thickness S within one hour for a unit temperature difference to adjacent room or outside air of 1 K (°C).

1 = Pilkington **Profilit**™ profile-type glazing glass (standard production) / SG = single glazing / DG = double glazing

S = special production - for production-related reasons these products are only manufactured on a per-order basis and are not kept in stock.

(\*) = sale from stock providing there are sufficient stocks available or from next production run

# Standard max. installation lengths for vertically installed Pilkington **Profilit**™ glazing

Pilkington **Profilit**™ panels sealed and not inclined

Design wind load kN/m <sup>2</sup>	Single glazing (flange inside)						
	K 22 L (m)	K 25 L (m)	K 32 L (m)	K 50 L (m)	K 22/60/7 L (m)	K 25/60/7 L (m)	K 32/60/7 L (m)
0.50	2.70	2.50	2.30	1.90	4.20	4.00	3.60
0.60	2.40	2.30	2.00	1.70	3.85	3.60	3.30
0.70	2.30	2.10	1.90	1.60	3.55	3.40	3.00
0.80	2.10	2.00	1.80	1.50	3.35	3.20	2.85
0.90	2.00	1.90	1.70	1.40	3.10	2.95	2.70
1.00	1.90	1.80	1.60	1.30	3.00	2.80	2.55
1.20	1.70	1.60	1.50	1.20	2.70	2.55	2.30
1.40	1.60	1.50	1.35	1.10	2.50	2.40	2.15
1.60	1.50	1.40	1.25	1.00	2.35	2.20	2.00
1.80	1.40	1.30	1.20	0.95	2.20	2.10	1.90
2.00	1.30	1.20	1.10	0.90	2.10	2.00	1.80
3.00	1.00	1.00	0.90	0.75	1.70	1.60	1.45

Design wind load kN/m <sup>2</sup>	Double glazing						
	K 22 L (m)	K 25 L (m)	K 32 L (m)	K 50 L (m)	K 22/60/7 L (m)	K 25/60/7 L (m)	K 32/60/7 L (m)
0.50	3.80	3.60	3.20	2.70	6.00	5.70	5.10
0.60	3.40	3.25	3.00	2.40	5.40	5.15	4.65
0.70	3.20	3.00	2.70	2.25	5.00	4.75	4.30
0.80	3.00	2.80	2.55	2.10	4.70	4.50	4.00
0.90	2.80	2.70	2.40	2.00	4.40	4.20	3.80
1.00	2.65	2.50	2.30	1.90	4.20	4.00	3.60
1.10	2.55	2.40	2.20	1.80	4.05	3.80	3.45
1.20	2.40	2.30	2.00	1.70	3.80	3.60	3.30
1.40	2.25	2.10	1.90	1.60	3.50	3.40	3.00
1.60	2.10	2.00	1.75	1.45	3.30	3.15	2.80
1.80	2.00	1.90	1.65	1.35	3.10	3.00	2.65
2.00	1.85	1.75	1.55	1.30	3.00	2.80	2.55
3.00	1.50	1.40	1.30	1.00	2.40	2.30	2.00

This table gives standard installation lengths in metres, for vertically installed Pilkington **Profilit**™ glass within closed buildings and should be used as a guide only. However the local national regulations referring to safety parameters still have to be taken into account. **In case of doubt or for questions please feel free to address the manufacturer's technical service department.**

# Pilkington **Profilit™** - Standard vertical glazing

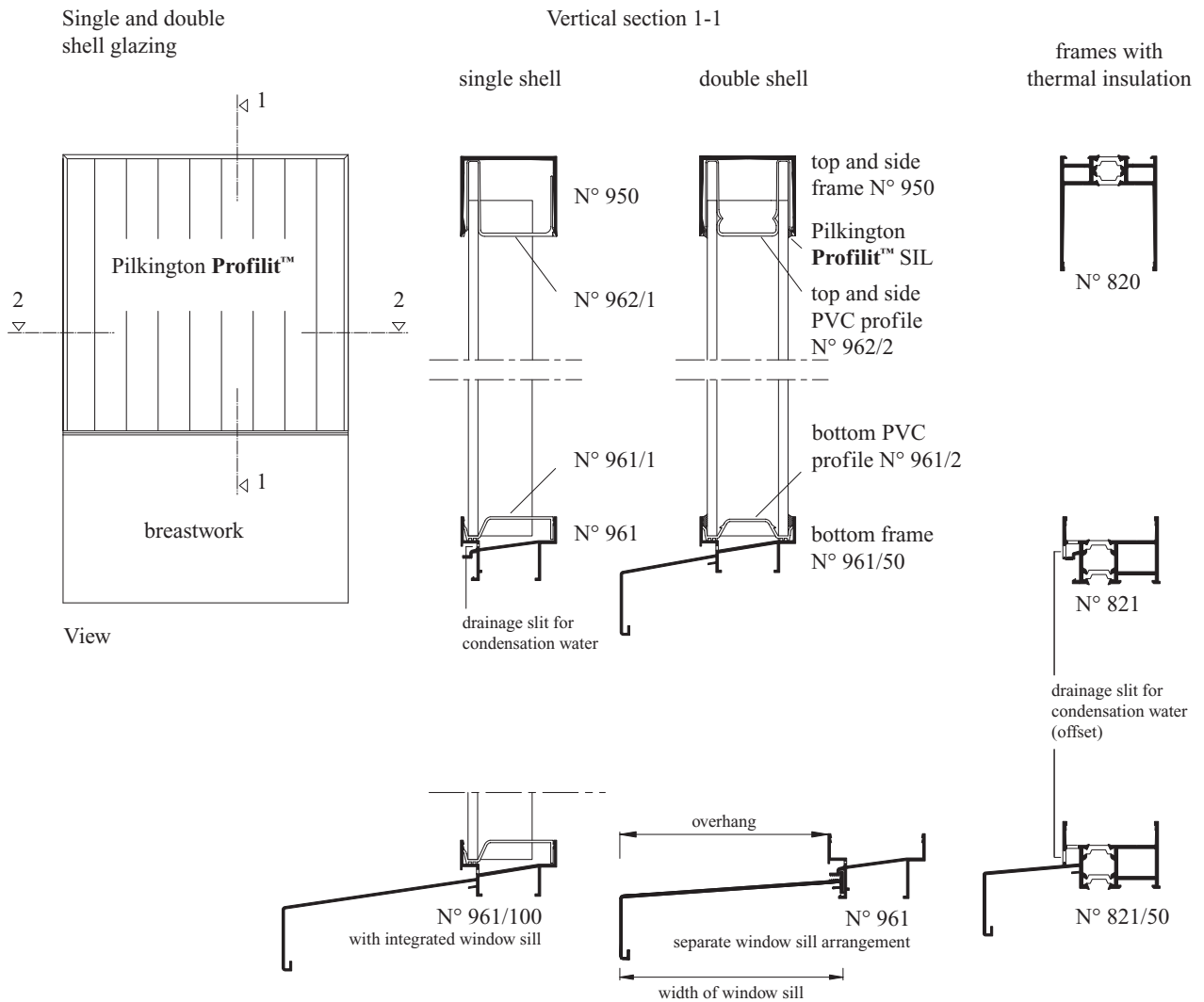

## Horizontal section 2-2

### Single shell glazing

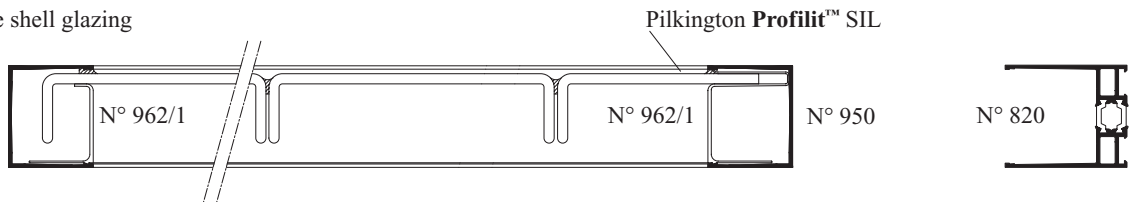

### Double shell glazing

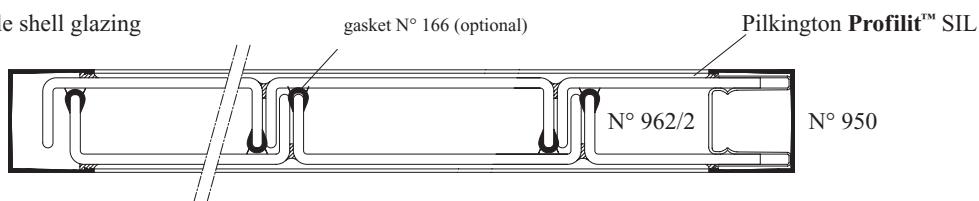

### Note:

The following pages 4 - 9 show illustrations of standard applications for which Pilkington **Profilit™** profiled glass can be used. In view of the wide range of application options for Pilkington **Profilit™** of which the details however cannot be shown here, please contact our applications technology department for any further advice.

# Pilkington Profilit™ - Special vertical glazing for sport halls

Double shell glazing

For sport halls see test certificate according to DIN 18032 part 3

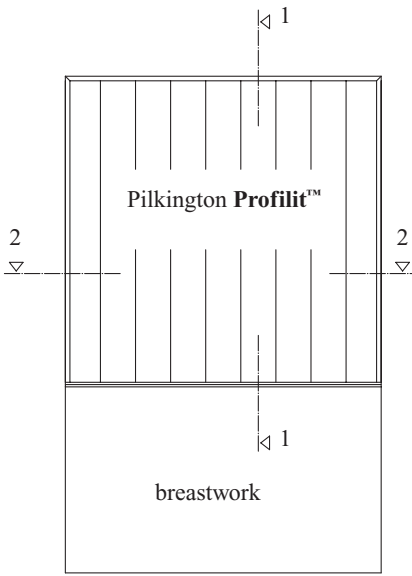

View

Vertical section 1-1

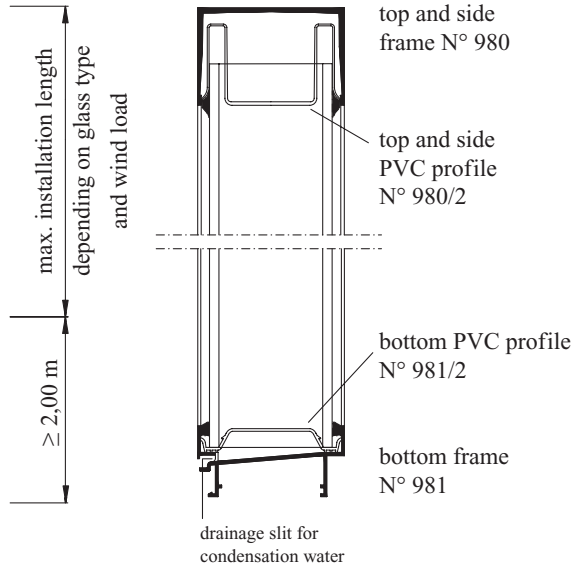

frames with thermal insulation

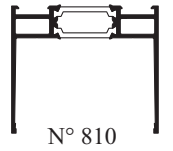

N° 810

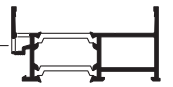

N° 811

possible for glass types K 22/60/7, K 25/60/7, K 32/60/7

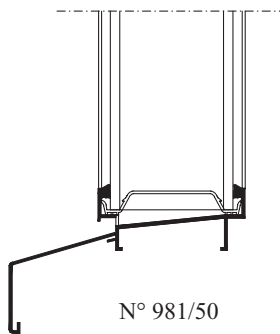

N° 981/50

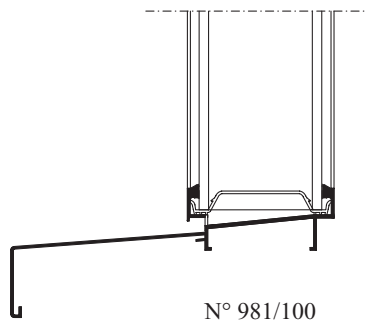

N° 981/100

drainage slit for condensation water (offset)

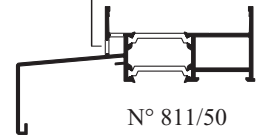

N° 811/50

Horizontal section 2-2

Double shell glazing

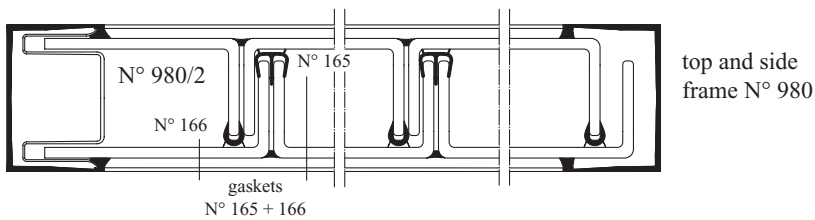

top and side frame N° 980

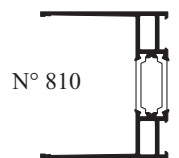

N° 810

# Pilkington **Profilit™** - Installation of ventilation shutters

Pilkington **Profilit™** installation system  
with ventilation shutter unit

The Pilkington **Profilit™** installation system  
is a modular system essentially comprising  
the following elements:

- High-quality **aluminium profiles** -  
available as mill finished, anodised, RAL  
coated or thermally insulated options

- **Plastic insert or support profiles** -  
high impact resistance, light resistance,  
weatherproof and non warping

- **Ventilation elements** -  
standard sizes or made to order;  
marry perfectly with the Pilkington **Profilit™**  
installation system, i.e. also available as  
thermally insulated option

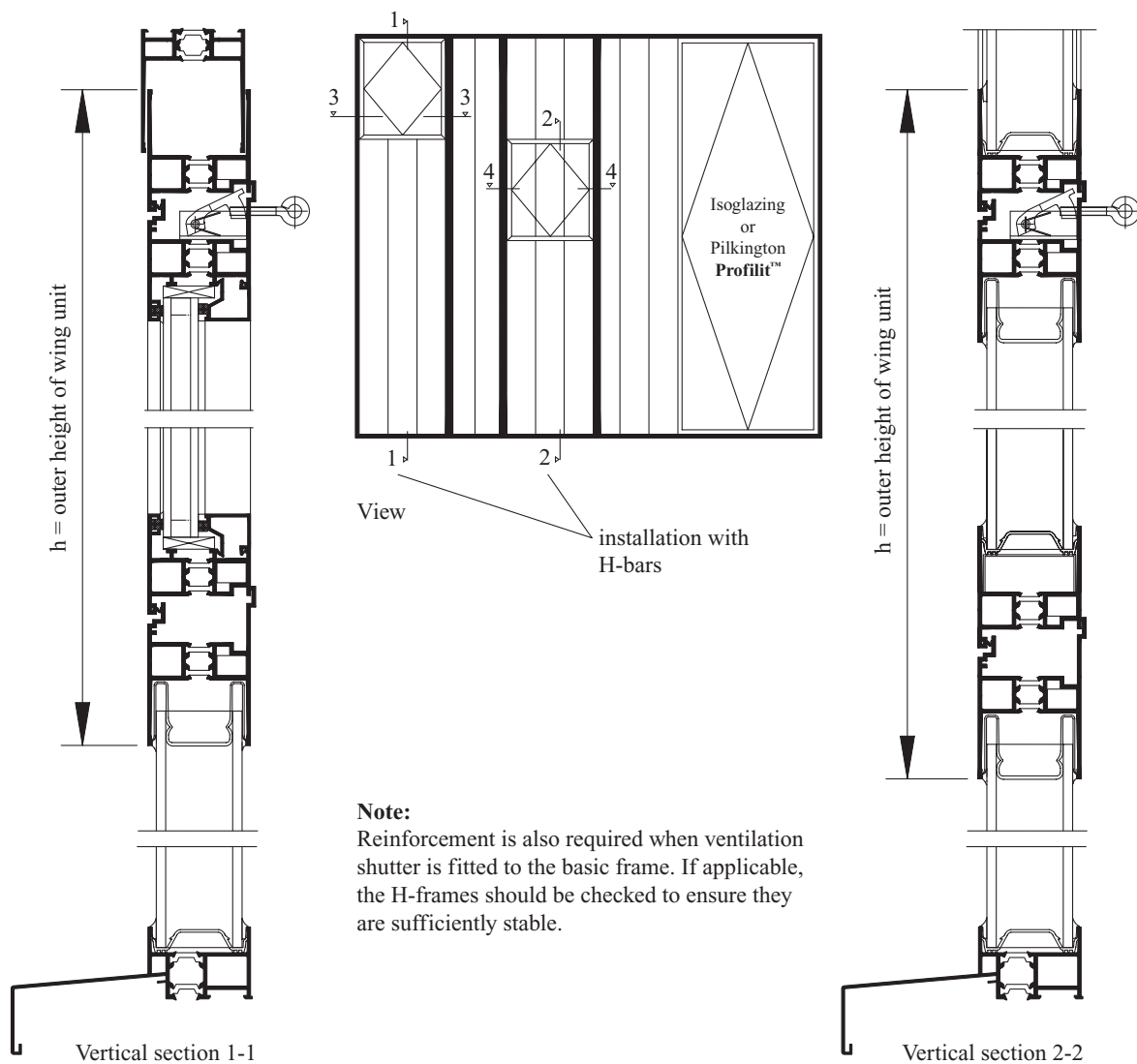

# Pilkington **Profilit**<sup>TM</sup> - Standard horizontal glazing

Double shell glazing

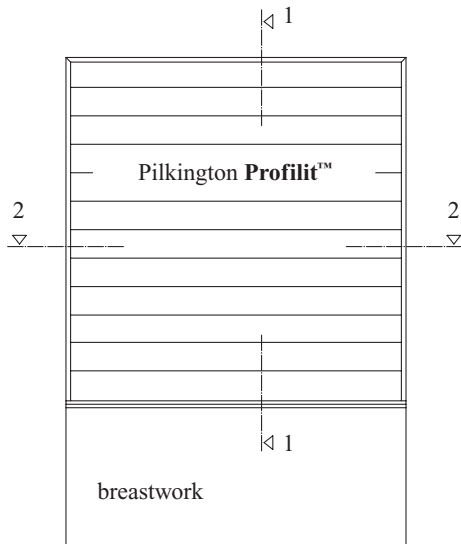

View

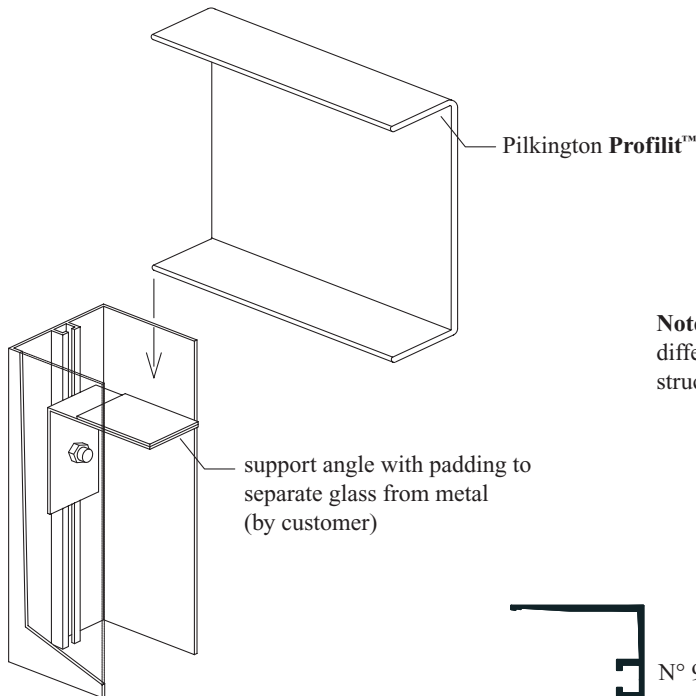
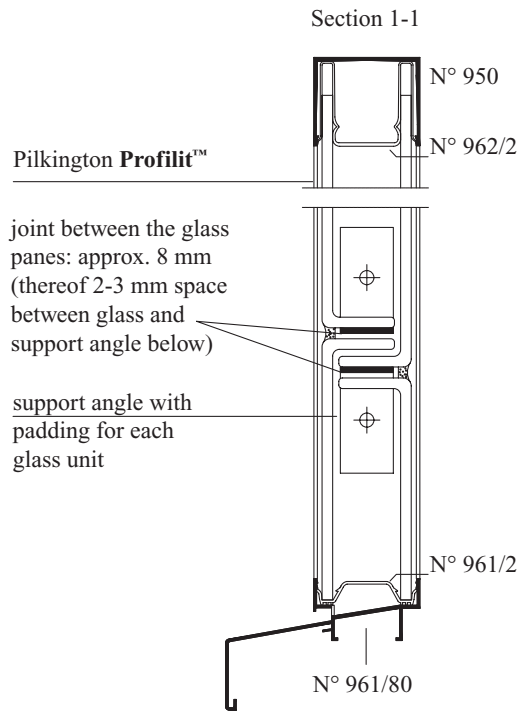

**Note:**  
different glass types require structurally designed support angles

Section 2-2

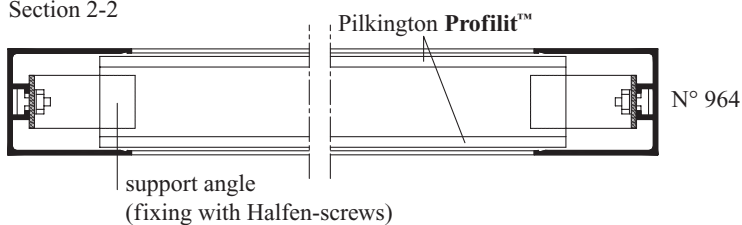

frames with thermal insulation

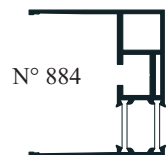
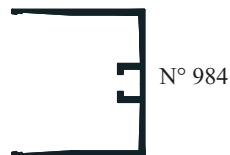

# Pilkington **Profilit™** - Profiles for fix window elements

The following sketches are showing Isoglazed elements integrated into the Pilkington **Profilit™** installation system.

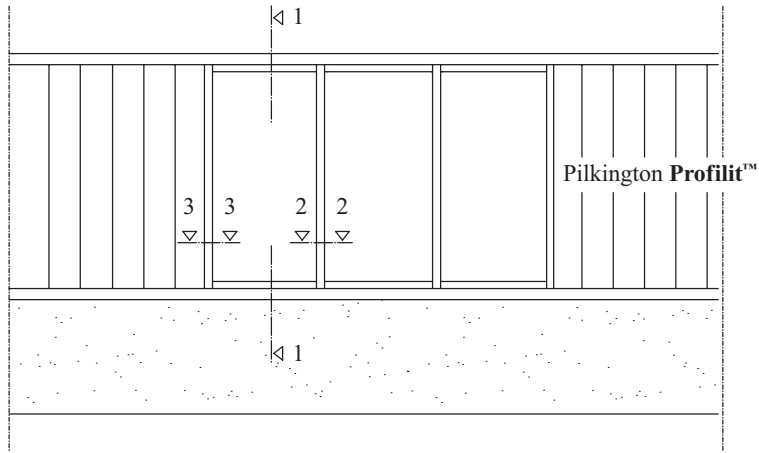

View

Section 3-3

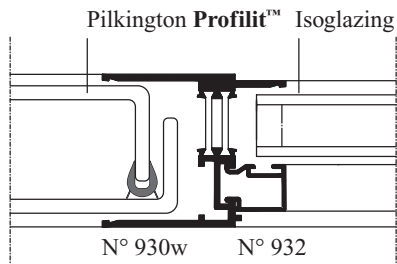

Section 1-1

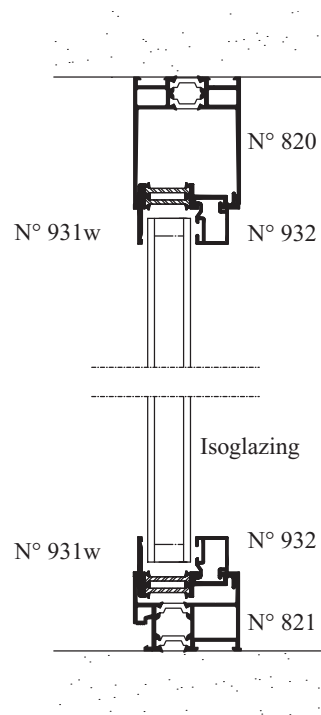

Section 2-2

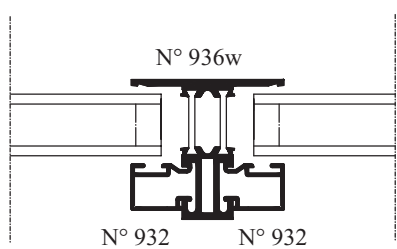



# Pilkington **Profilit**<sup>TM</sup> - Roof glazing (vertical shed glazing)

Double shell glazing

System sketch

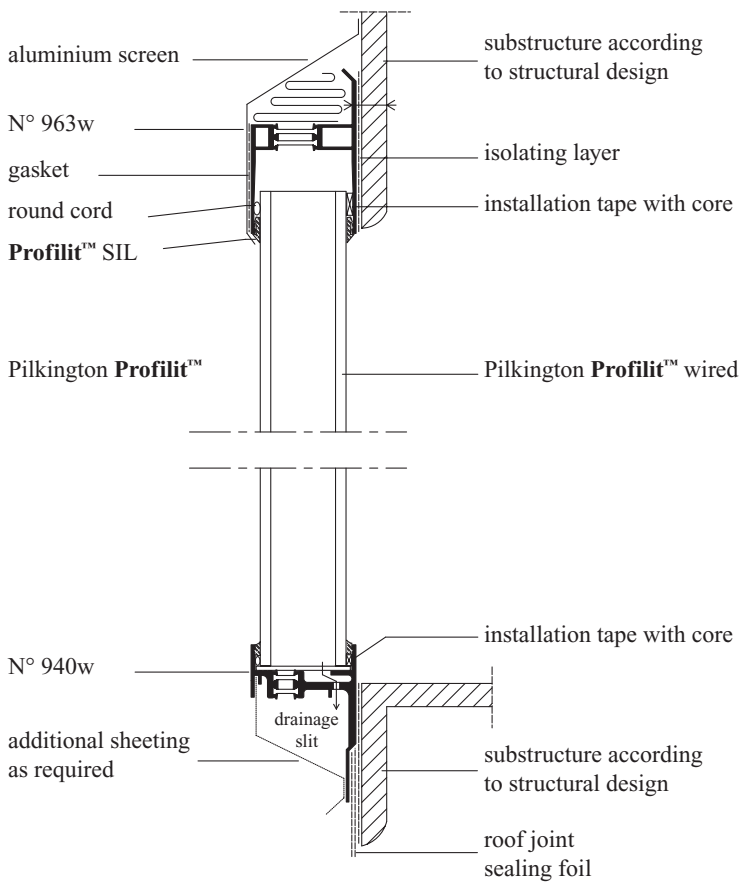
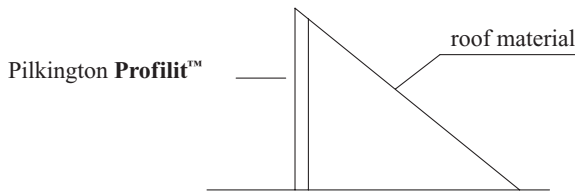

**Note:**

No details concerning roof joints, heat-insulating measures, etc. are given here.

The drainage slits for condensation water made by customers are depending on the fixing of the frames and the inclination of the glazing. Max. frame loading in case of vertical installation (e.g. non bearing facades) - double layer - due to weight of glass  $l \leq 3.50$  m! Max. interval between bolts of 20 cm. In case of thermal broken frame N° 940w  $l \leq 3.00$  m.

# General text for tender (recommendations) for Pilkington **Profilit™** - Profiled glass with system

General survey

## Contents:

- I) Standard profile (NP) glazing with Pilkington **Profilit™** frame profiles installed vertically as a row of windows
- II) Special profile (SP) glazing with Pilkington **Profilit™** frame profiles installed vertically as a row of windows
- III) Sports hall glazing systems as per DIN 18032 with the Pilkington **Profilit™** profiles K22/60/7, K25/60/7 and K32/60/7 and Pilkington **Profilit™** frame profiles installed vertically as row of windows
- IV) Pivoted casements, for installation in Pilkington **Profilit™** glass walls (standard profiles - series 60)
- V) Hinged wing units for installing in Pilkington **Profilit™** glass walls (special profiles - series 83)

# General text for tender (recommendations) for Pilkington **Profilit™** - Profiled glass with system

The recommendations for tendering are available as download (WORD- or PDF-file) on the homepage [www.pilkington.com](http://www.pilkington.com) ([www.profililit.com](http://www.profililit.com)) and in the **technical manual (CD-ROM)**.



accessibility site map

**PILKINGTON**

de home über pilkington was gibt es neues presse beruf und karriere downloads alles über glas kontakt corporate site

deutsch \ bauglas \ profilglas \ downloads

### Downloads

- › [Allgemeiner Produktprospekt](#)
- › [Allgemeine bauaufsichtliche Zulassung](#)
- › [Fassadenprospekt 2001](#)
- › [Fassadenprospekt 2003](#)
- › [Fassadenprospekt 2005](#)
- › [Ausschreibungsempfehlung D \(Word\)](#)
- › [Ausschreibungsempfehlung D \(PDF\)](#)
- › [Lieferprogramm Pilkington Profilit™](#)
- › [Profilglaszeichnungen](#)
- › [Funktionsgläser](#)
- › [Einbaulängen](#)
- › [Einbausysteme](#)
- › [Referenzen](#)

### Downloads in English language

- › [General Brochure](#)
- › [Facades Brochure 2001](#)
- › [Facades Brochure 2003](#)
- › [Facades Brochure 2005](#)
- › [Text for tender \(WORD\)](#)
- › [Text for tender \(Pdf\)](#)
- › [Product range](#)
- › [Installation length](#)
- › [Installation components](#)
- › [References](#)

**Link to this page:** <http://www.pilkington.com/europe/germany/german/building+products/profililit/weitere+downloads.htm>

The manufacturer reserves the right to change or discontinue any specification or products without notification. All goods are subject to availability.

This publication gives a general description of the product and materials and should be used as a guide only. It is the responsibility of the user of this document to ensure that the use of the

Pilkington **Profilit**™ System is appropriate for any particular application, and that such applications comply with all relevant local and national legislation, standards, codes of practice and other requirements. Bauglasindustrie GmbH hereby disclaims all liability, howsoever arising, from any error in or omission from this publication and the consequences of relying upon it.



CE marking confirms that a product complies its relevant harmonised European Norm.

The CE Marketing label for glass products, including declared values, can be found at [www.pilkington.com/CE](http://www.pilkington.com/CE).



**PILKINGTON**  
NSG Group Flat Glass Business

**Bauglasindustrie GmbH**

Hüttenstraße 33 66839 Schmelz

Phone +49 (0) 6887 303 0 Fax +49 (0) 6887 303 45 E-Mail [profilbauglas@pilkington.de](mailto:profilbauglas@pilkington.de)

[www.pilkington.com](http://www.pilkington.com)